



Reliable Food-Safe Scale for Dry Environments

With a food-safe design that is NSF certified, the Valor 1000 series is a reliable choice for general food weighing. Easy-to-operate, Valor 1000 scales feature two-button operation, large backlit LCD display and up to 1,500-hour battery life.

Standard Features:

- **Easy-Clean, Hygienic Design**
NSF-listed design supports HACCP systems with durable ABS housing and removable stainless steel pan, making Valor 1000 suitable for food preparation and portioning applications.
- **Low Power Consumption Design Promotes Continuous Use**
Save money on batteries. Energy-efficient design operates for up to 1,500 hours.
- **Easy Two-Button Operation**
Intuitive two-button operation allows for quick weight checking to simplify repetitive operations and increase operator efficiency.

VALOR®1000 - V12P Compact Bench Scales

Model*	V12P3	V12P6	V12P15	V12P30
Capacity × Readability (Max x d non-approved)	3 kg x 0.0005 kg 3,000 g x 0.5 g	6 kg x 0.001 kg 6,000 g x 1 g	15 kg x 0.002 kg 15,000 g x 2 g	30 kg x 0.005 kg 30,000 g x 5 g
Maximum Displayed Resolution	1: 6,000	1: 6,000	1: 7,500	1: 6,000
Weighing Units	g, kg, lb, oz, lb:oz			
Application Mode	Weighing			
Tare Range	To capacity by subtraction			
Stabilization Time	≤ 2 seconds			
Power Requirements	Four Type D cell Alkaline batteries (included), AC adapter or rechargeable battery (optional)			
Calibration	Digital with external weight			
Battery Life	1,500 hours (with backlight turned off)			
Construction	ABS plastic housing and stainless steel pan			
Safe Overload Capacity	150% of capacity			
Specified Temperature Range	0 to 40° C			
Display	Single display - LCD with white backlight			
Display Size	25.4 mm			
Pan Size	245 x 190 mm			
Scale Dimensions (W x D x H)	260 x 270 x 122 mm			
Shipping Dimensions (W x D x H)	319 x 319 x 175 mm			
Net Weight	2.5 kg			
Shipping Weight	3.1 kg			

*Certain regions are available with V12PRx models, which are standard with AC adapter and rechargeable battery.

Other Standard Features and Equipment

Integrated level bubble and adjustable feet, selectable Auto-Off, selectable weighing units and integrated carrying handles for easy transportation

Compliance

- **Product Safety:** IEC/EN 61010-1; UL certified power supply
- **Electromagnetic Compatibility:** IEC/EN 61326-1 Class B, Basic environments
- **Food Equipment:** ANSI/NSF 169
- **Compliance Marks:** CE; NSF; RCM; WEEE

Accessories

Stainless Steel Platform, 193 x 248 mm	30559102	Adapter, 10W, 12VDC, Main Body	46001812
In-use Cover (1)	30559105	EU Plug	46001774
Rechargeable Battery Kit	30559104	AU Plug	46001775
Stainless Steel Platform, 300 x 225 mm	30559107	UK Plug	46001777
In-use Cover (10)	30559106	US Plug	46001776

Outline Dimensions

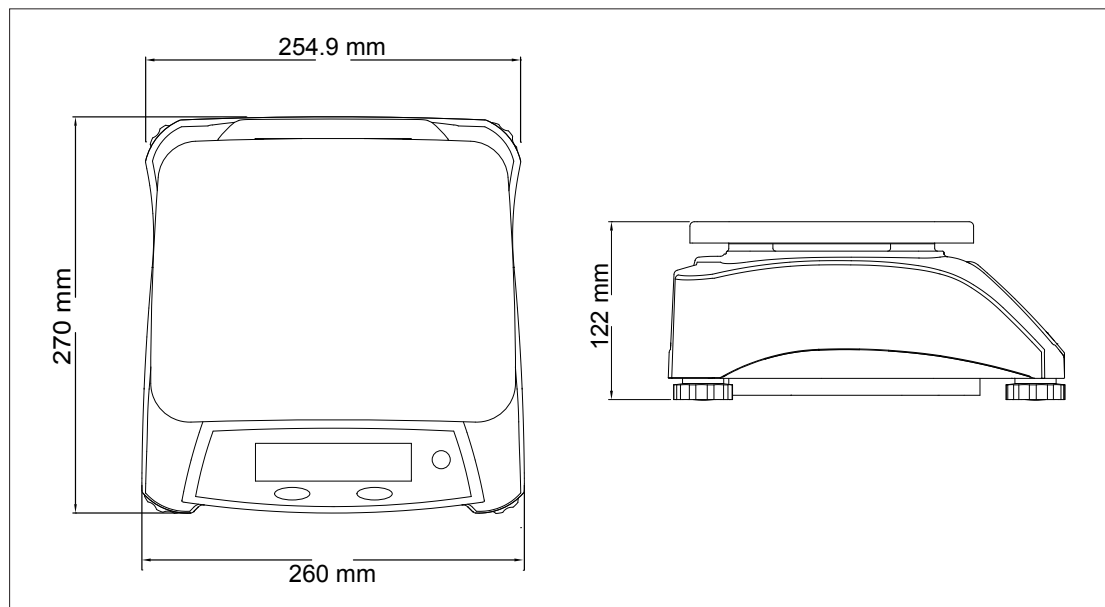

OHAUS Asia/Pacific Headquarters

7F, Block 33, 680 Guiping Road
Shanghai 200233
China

e-mail: APmarketing@ohaus.com
Tel: +86 21 64855408

www.ohaus.com

The management system
governing the manufacture
of this product is
ISO 9001:2015 certified.

SAP Literature #

